

ATOM LOW-OFFSET AUTOMATIC SYSTEM

Features:

- Ability to cover pools 50' length
- Ability to cover pools 20' width
- Adjustable Slip Clutch
- Many of the same features found in the Eclipse system but in a compact package!
- Fits into a 24" Motor End Vault
- Drains in the housing are required!

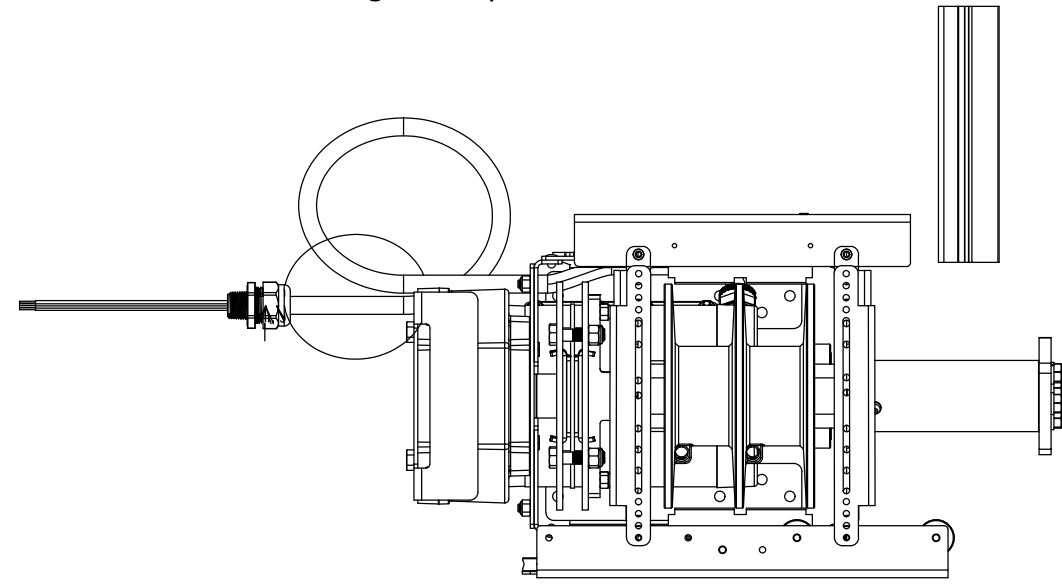
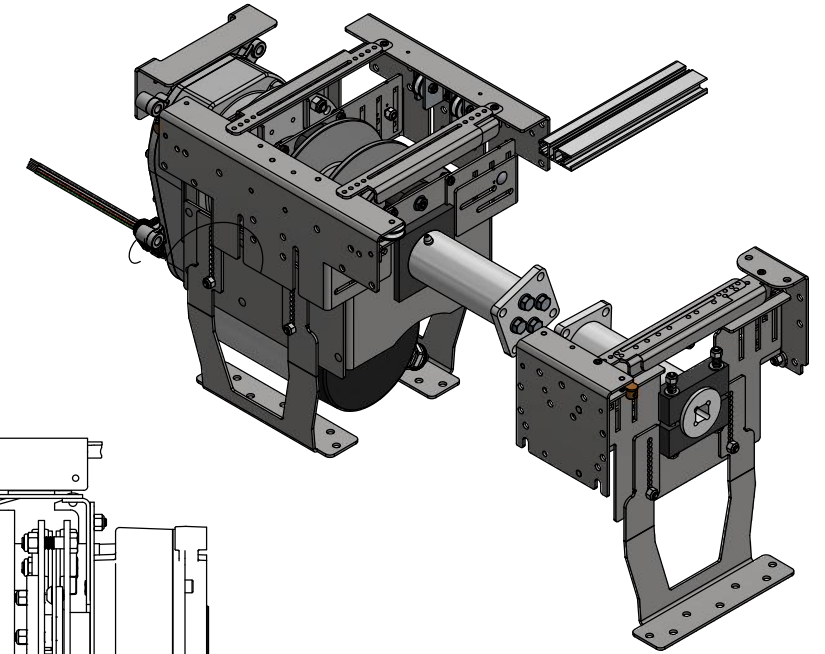

Width Adjustment

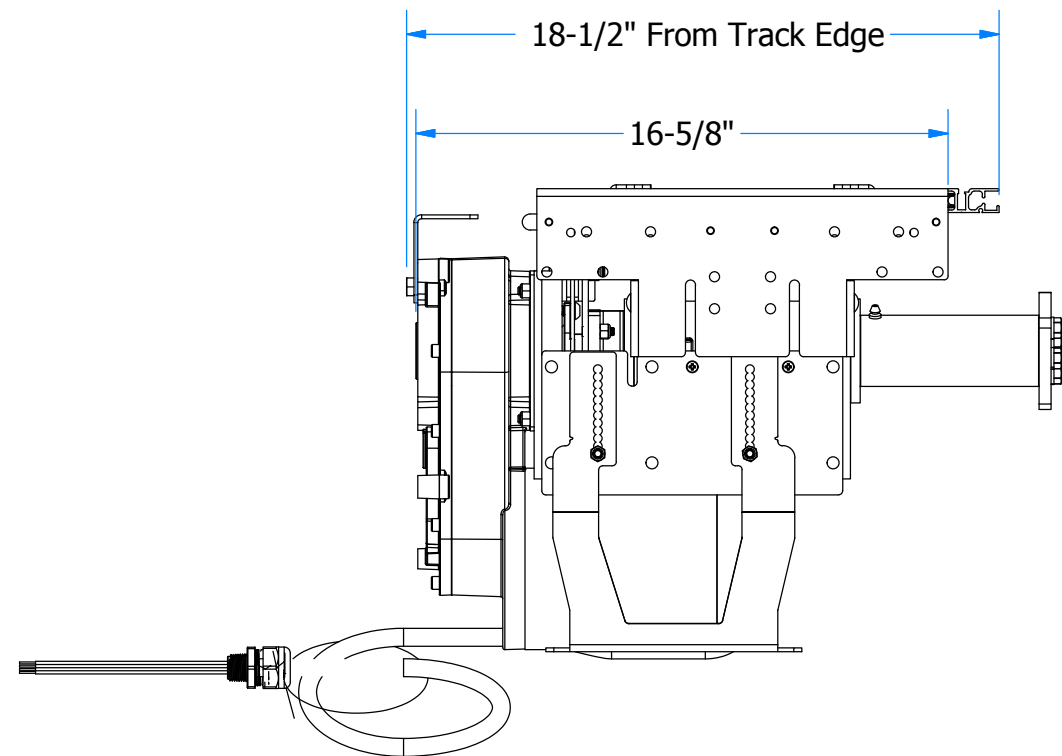
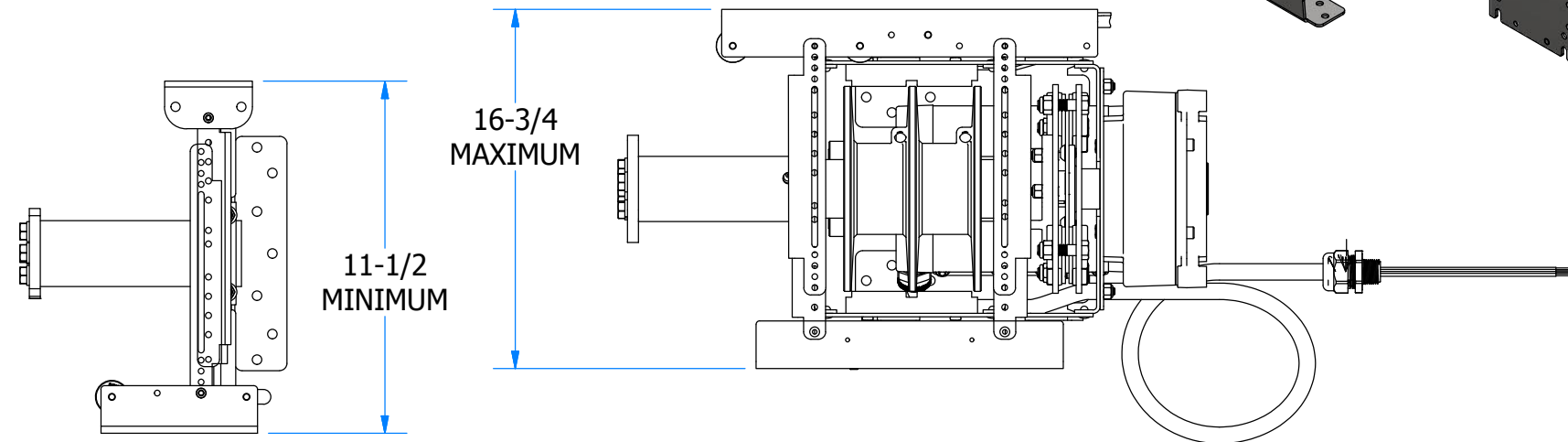

Height Adjustment

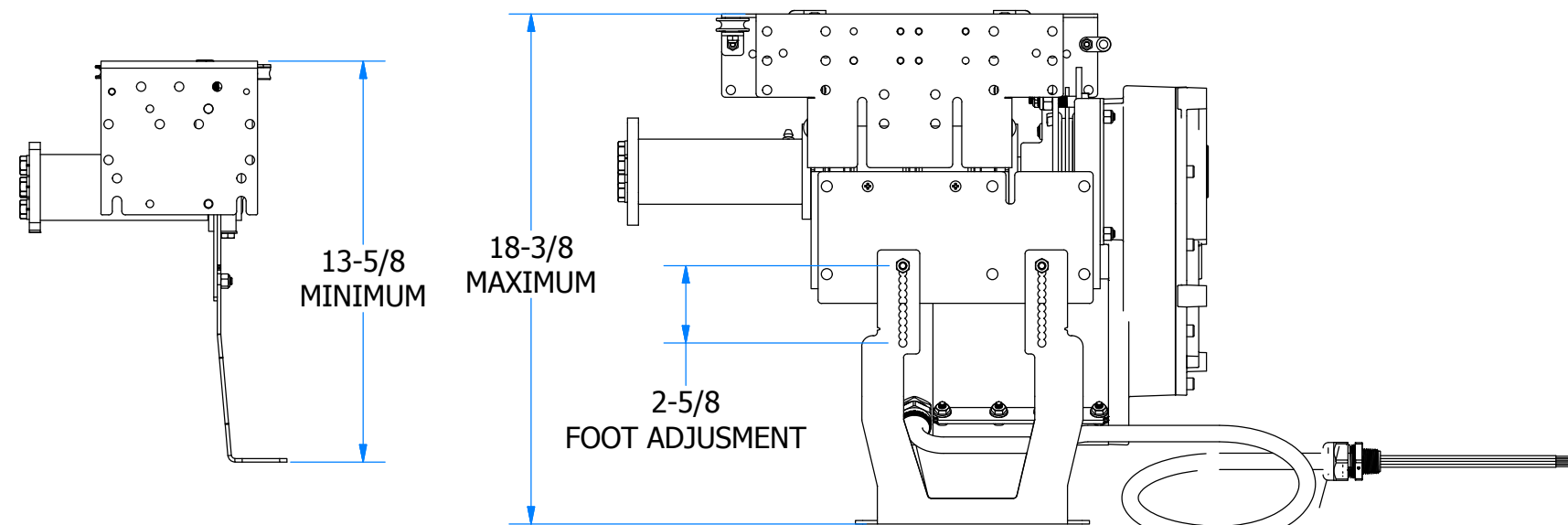



Concrete Cover Housing for Low-Offset System

ELECTRICAL ALL-WEATHER JUNCTION BOX WILL NEED TO BE MOUNTED TO THE SIDE OF THE VAULT, OR RECESSED INTO THE END OF THE VAULT. THE CONDUIT STUB WILL NEED TO BE RAN TO THIS LOCATION

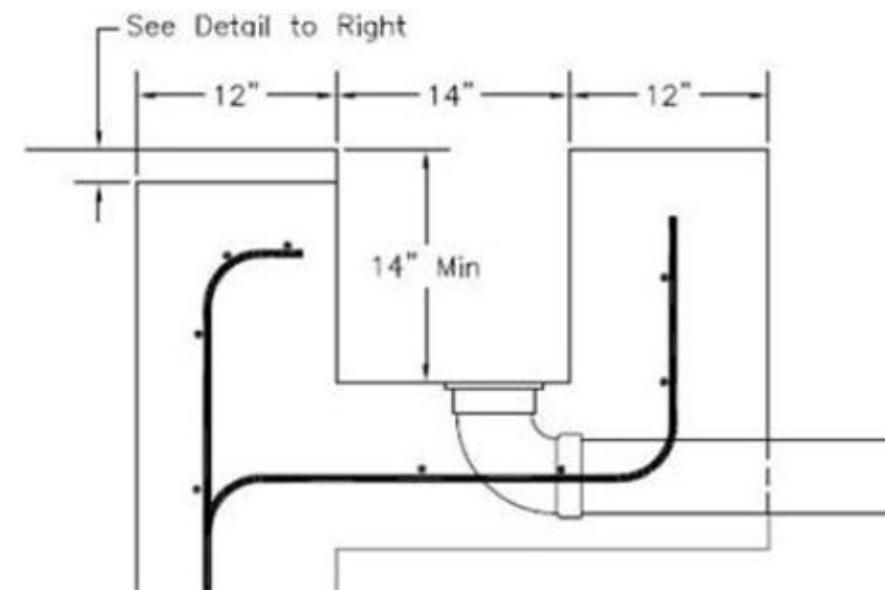
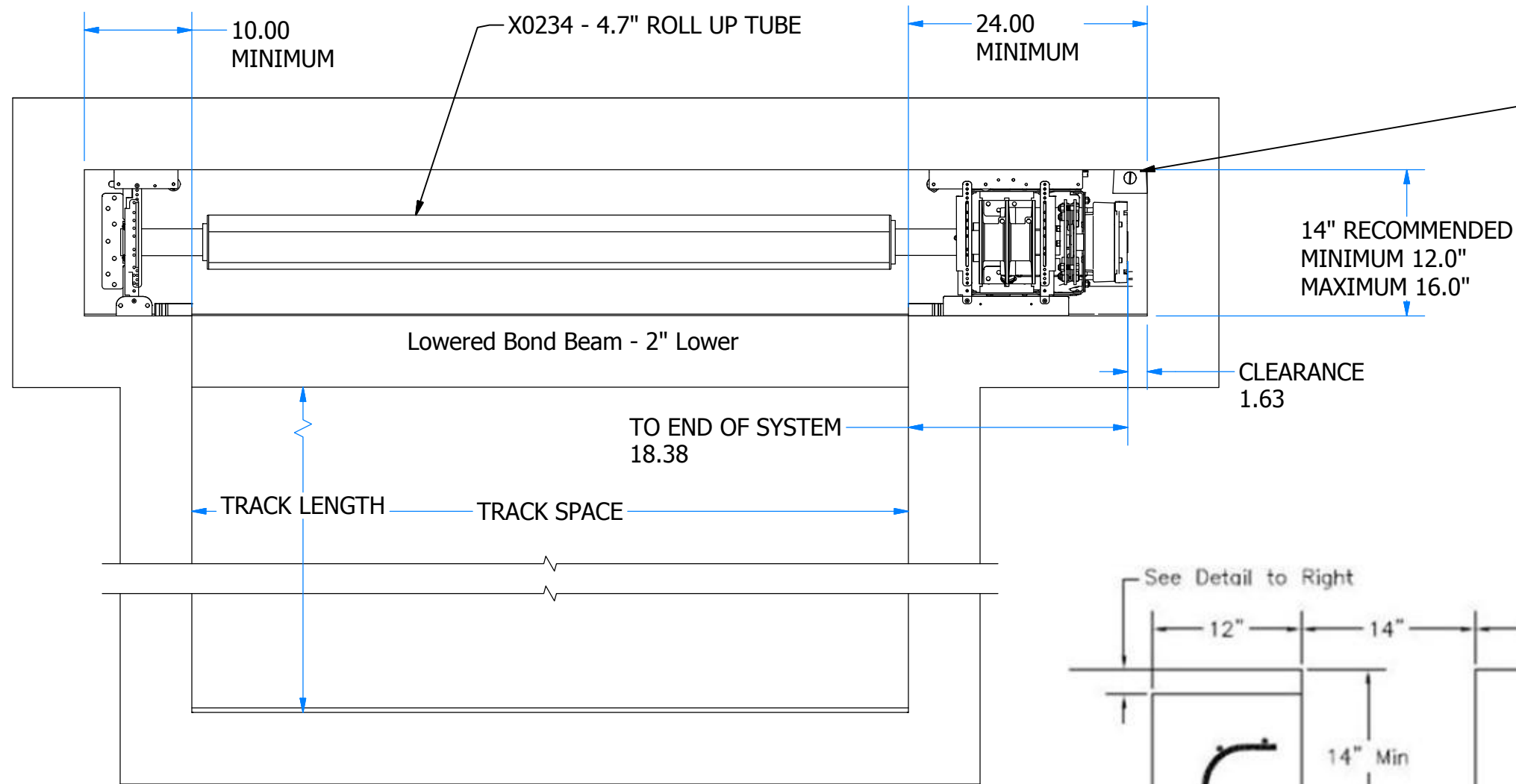

Because coping and deck thickness vary, housing depth is always measured from the top of beam or top of encapsulation.

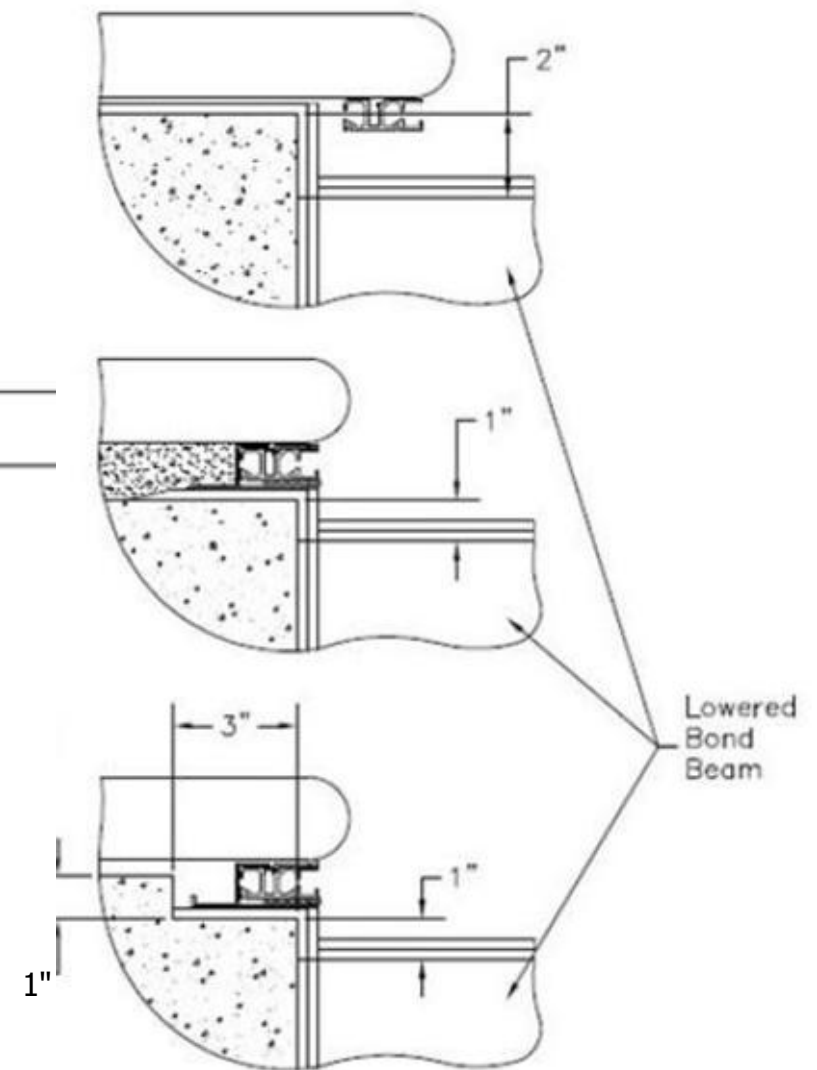

Concrete cover housing may be shaped and formed free hand or shot around a form. Walls must be straight and plumb, make housings square to pool. Steel cover housing walls same as pool. Do not allow rebound to be used for housing walls.

This cover housing show a motor-left, but motor can be on either side. The motor-end offset is minimum 20" from the inside edge of pool wall. The non-motor-end minimum offset is 9" from the inside edge of the pool wall.

The lowered bond beam is 2" lower for screw on guide applications and when notching bond beams for encapsulation. Lowered bond beam is 1" lower when using encapsulation on top of bond beams. Cover housing walls are same height as side wall bond beams and are 12" thick to support stone lid brackets. Also allows 12" wide decking material to be mortared on top of housing walls.

Inside of housing is 14" wide and 14" deep from side wall bond beam elevation for pools up to 55' long or up to 25' wide. Low-Offset system has a Maximum length of 55' and Maximum width of 20'.

Stub drain before gunite. If using a form, use closet flange to attach drain stub to form. Drain(s) must be 3" minimum and drain to open air. If this is not possible a adequately sized drywell or pump out pit should be used. The drain must work!

Sub conduit or chase for conduit/hydraulic hoses through end wall or motor side 3" below top, Electric must be finished with all-weather junction box.